

S.NO	CATALOG NUMBER	L	N	SCREW SIZE
1	NACC600-2A	2.72 [63]	2	13/16-16
2	NACC600-3A	4.00 [95]	3	13/16-16

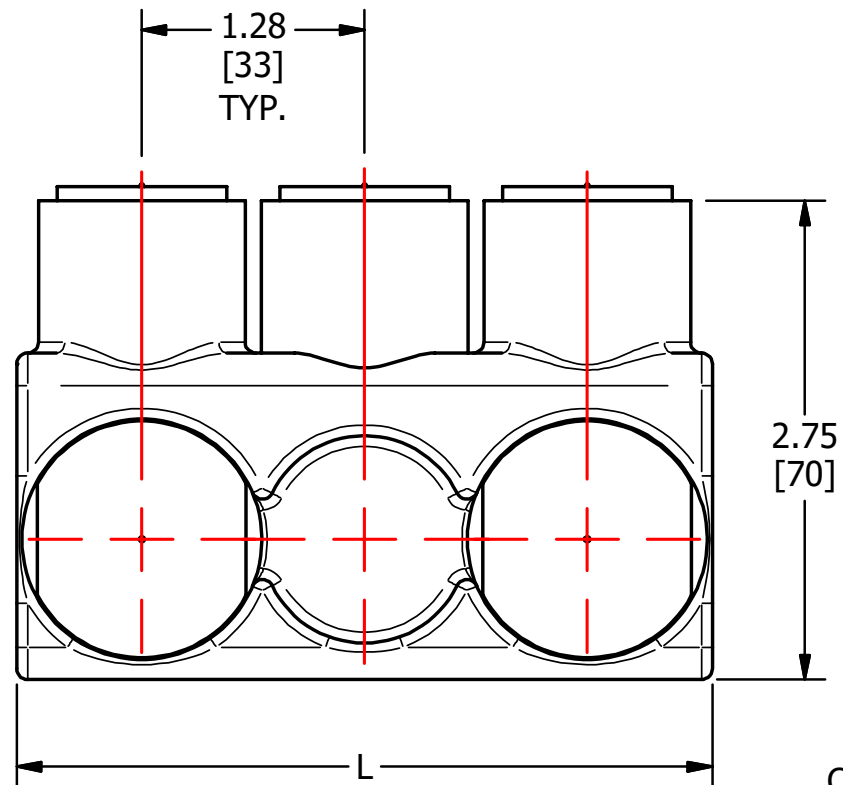
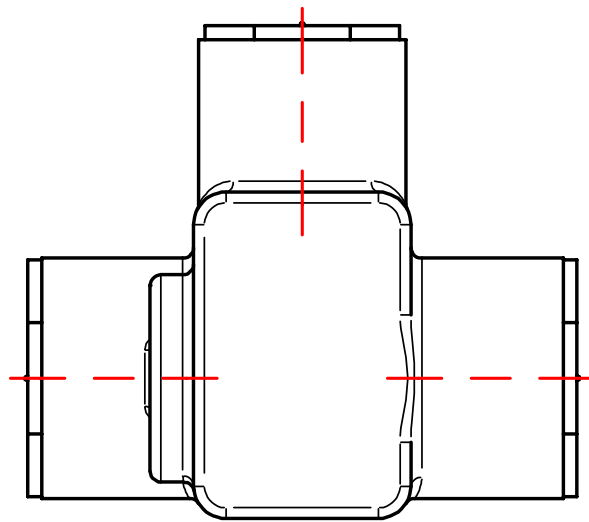
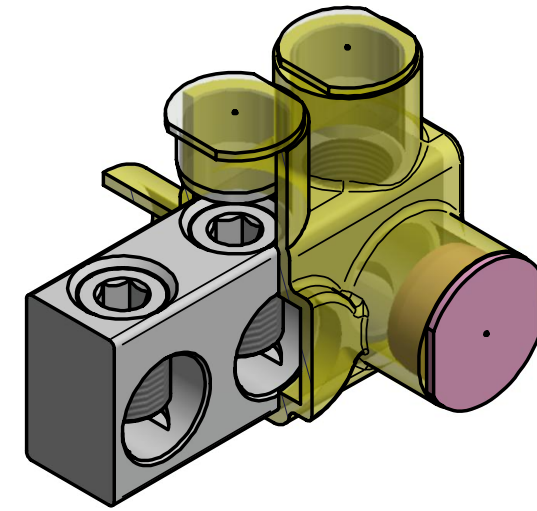
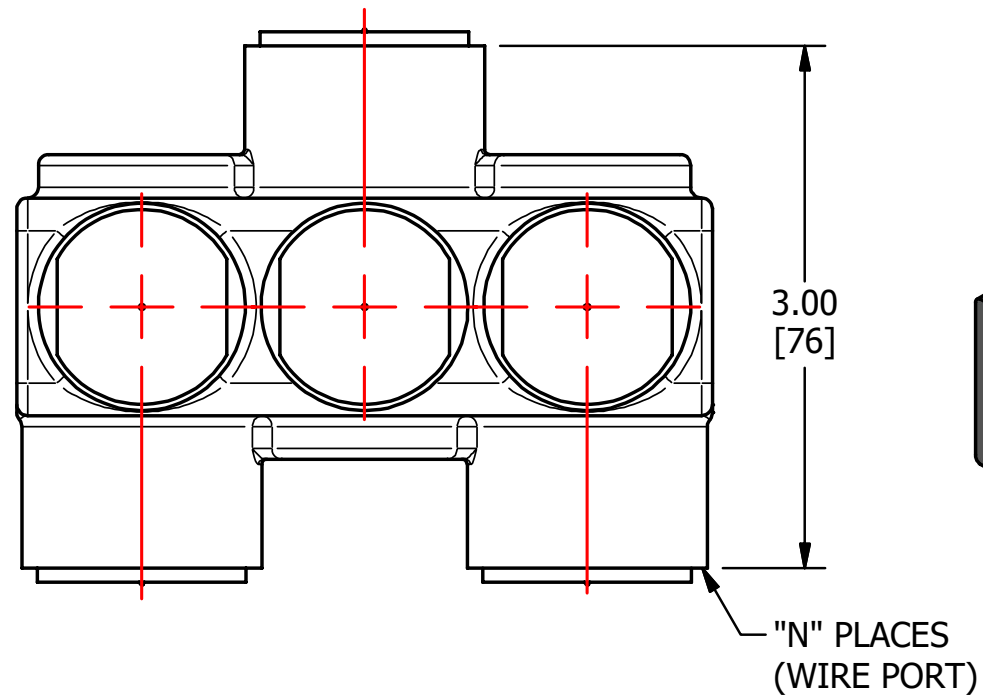

CONNECTOR FINISH: CLEAR PLATE
CONNECTOR MATERIAL: ALUMINUM
CONDUCTOR RANGE: 600 Kcmil - #4 AWG
ENCAPSULE MATERIAL: CLEAR PVC

					TO ORDER CMC PRODUCTS CALL 1-513-860-4455	DRAWN BY: TS 09-24-19	NAME OF PART: ENCAPSULATED BAR ASSEMBLY	CAT. NO.: SEE TABLE
					FOR PRODUCT INFO: http://www.cmclugs.com	CHECKED BY:	DWG NO: C58701685-S (CHARTED)	A
A	NEW DRAWING CREATED		09-24-19	TS		DRAWING NOT TO SCALE		SHEET NO: 1 OF 1
REV.	DESCRIPTION	ECN	DATE	INIT.				

THIS INFORMATION IS PROPRIETARY TO CONNECTOR MFG. CO. AND IS NOT TO BE DISCLOSED OUTSIDE OF CONNECTOR MFG. CO. WITHOUT A CONFIDENTIALITY AGREEMENT



CONNECTOR MANUFACTURING CO.

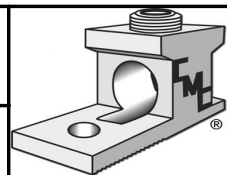

HAMILTON, OHIO